

Spherical roller bearings, cylindrical and tapered bore

Principal dimensions			Basic load ratings		Speed ratings	Limiting speed	Designation
d	D	B	dynamic C	static C0	Reference speed		
mm			kN		r/min		<b>* SKF Explorer bearing</b>
<b>460</b>	680	163	4065	6950	560	950	23092 CAK/W33 *

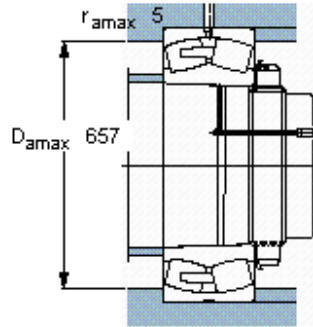
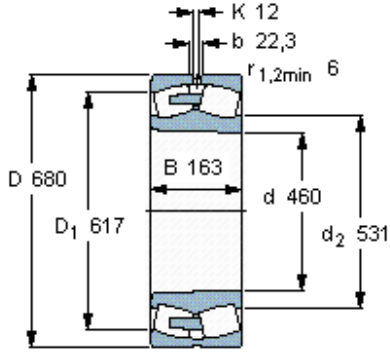

Tapered bore, taper  
1: 12

- Calculation factors**
- e 0,22
  - $Y_1$  3
  - $Y_2$  4,6
  - $Y_0$  2,8